

# **MICROCONTROLLER BASED AUTOMATIC COLLEGE BELL** **WITH MONITORING SYSTEM**

Shweta Butoliya, Nupur Shal, Snehal Girhepunje,

Aakanksha Rannaware,Prerna Baddalwar, Vaishali Badwe

Guided By Prof. S.A.Bagal

Electronics and Telecommunication Engineering,Smt Rajshre Mulak College of engineering for  
Women, Nandanvan, Nagpur, India

## **Abstract:**

*Now a days there is use of automation in every sector. Here we are presenting a new model. This model of ringing bell is used everywhere from schools to colleges. It avoid the human help with accuracy as it is automatic. It uses Real Time Clock(DS1307) which track the real time . The microcontroller P89V51RD2 is used to control all the functions through program. When this programmed time equals the real time then the bell is switched ON via Relay for predetermined time at normal class timings as well as exam times.*

*Also we are using “GSM based LED Scrolling display Board” for displaying notices/messages at the*

*places which require the real time, by sending SMS containing message through mobile. The SMS is deleted from the SIM each time it is read, thus making room for the next SMS.*

## **I. INTRODUCTION**

The task of ringing bell automatically is carried out by this project. It has an inbuilt Real Time Clock which shows the real time. When this real time equals to the bell ringing time then bell is switched ON following relay. The time is display on LED Scrolling Display Board. Using this project we implementation the idea of wireless communication between mobile phone and display board. This project include the following main components.

- Microcontroller-Philips P89V51RD2
- GSM modem-SIM 300
- Real Time Clock
- MAX 232 level converter
- 7\*48 LED display
- Shift Register 74HC595

- TIP 125/127
- Current limiting Resistors – 100 Ohm

The user uses a simple GSM based handset for sending message to display board. By using proper AT commands, GSM modem used to receive the msg at the receiver end which is read by the modem and stored in the microcontroller. In order to reduce the number of pins and to simplify the hardware this design uses “Charlieplexing Technique”. In this technique the LED’s can be connected in common anode or cathode configuration.

## II. BLOCK DIAGRAM

The block diagram of the system is shown in figure1.

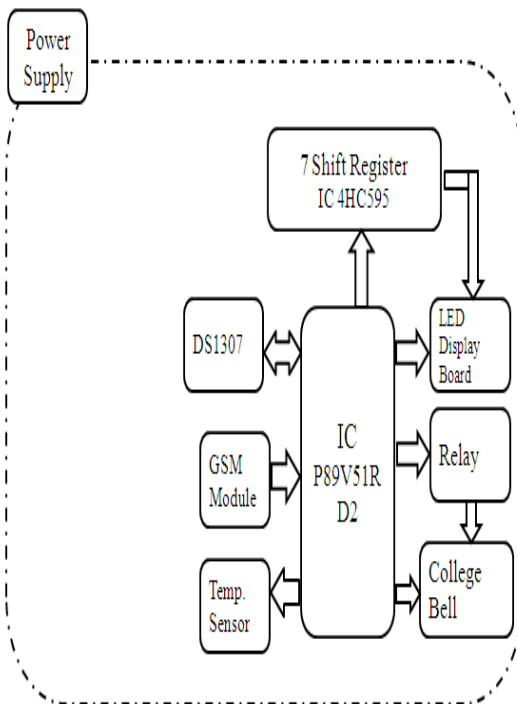

**Fig 1 : Block Diagram of microcontroller based college bell with monitoring system**

## III. CIRCUIT DIAGRAM

There are three major interfacing circuits :

1. The microcontroller is interfaced with bell via relay.
2. The microcontroller is interfaced with modem via MAX 232 level convertor.
3. The microcontroller is interfaced with the LED display board.

The circuit diagram is shown in figure 3.

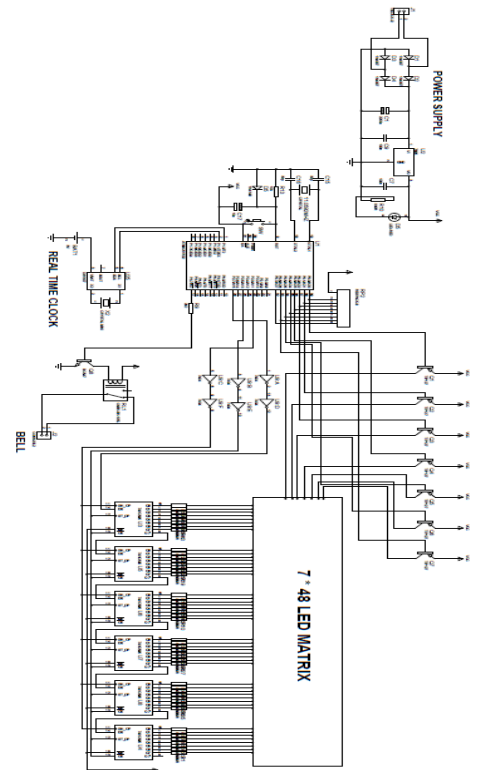

**Fig 2 : Interfacing of microcontroller with LED Display Board and College Bell**

## IV. HARDWARE PROFILE

### **A. Microcontroller Philips-P89V51RD2**

P89V51RD2 is a powerful 40 pin microcontroller which provides a range of features such as:

- 80C51 Central Processing Unit
- 64kB of on chip Flash program memory with ISP(In-System Programming)
- 64kB Flash memory
- 1024 bytes of data RAM
- Four 8 bit I/O ports

The microcontroller transmits AT commands to receive the message which is sent by the user.

### **B. GSM Modem- SIM 300**

The GSM Modem can accept any GSM network operator SIM (Subscriber Identity Module) card and act just like a mobile phone with its own phone number. And can be used to send SMS, make and receive calls, and do other GSM operations by controlling it through simple AT commands from microcontroller and computers.

### **C. Real Time Clock**

Real Time Clock(RTC) is 8 pin IC which counts seconds, minutes, hours, date of the month, month, day of the week, and year with a leap year. It has 56-byte nonvolatile RAM for data storage with battery back up. It is also have the capacity of detecting the

power off hence automatically switches to battery supply.

### **D. Max-232 level converter**

The MAX-232 IC that converts signals from an RS232 serial port to signals suitable for use in TTL compatible digital logic circuits.

### **E. 7\*48 Display**

In 7\*48 LED display the Charlie-plexing technique is used to connect the LED's. Here we are using acrylic board to place 336 LED's. The advantage of this technology is that it reduces the number of pins required to drive the LEDs.

## **V. WORKING**

The GSM modem communicate with the microcontroller through universal asynchronous trans-receiver pin of IC P89V51RD2, which is used for serial communication. The baud rate used here is 9600. At the initial stage the values of SCON, TMOD and TH1 are set. The microcontroller transmits a set of AT commands to read the message. LED display board accomodates 336 LED's (7\*48 LED display) with 7 rows and 48 columns. As we know 1 character is of 8 bit we are using 6 shift register IC's are connected in cascading to shift each character column by column. The controller is supplied with the standard character set containing alphabets, symbols, numbers and special characters through programming. For each such character display pattern in the form of HEX value is stored inside the

microcontroller which is termed as look up table. After check for the pattern the microcontroller send out the data bits serially with clock signal. This data is shifted by the shift registers. The data is sent on columns and rows are scanned fast which make us feel that the pattern to be displayed is in continuation and this happens because of persistence of vision.

The microcontroller only keeps the message part and discards the remaining message.

## **VI. CONCLUSION**

This project explain how we can avoid the manual operating of bell by replacing it with automatic college bell circuitry. This automatic college bell not only used for 7 hours lecture schedule but also we can used it for examination purpose. We have constructively combine the college bell with GSM based LED scrolling board, to display the notices. This model can be perfectly used in hospital to display the availability of doctors in multispeciality hospitals again at bus stand to show the departure and arrival of different buses and at many more places.

## **VII. REFERENCES**

1. Hardik Gupta, Puja Shukla, Ankita Nagwekar, GSM based LED Scrolling Board : IJSRT, Vol 1 (3), ISBN [978-93-83006-01-4], May 2013.
2. Sheenu Choudhary, Shrikant and Priyanka Sharma, Automatic College Bell System : IJSRM , Vol (2), Issue(3), 2014.
3. Mrs. S.P. Gaikwad, Manikeshwari Shahdeo, Meghna Priya, Prashant Kr. Raghav, Wireless GSM Based Electronic Notice Board.
4. The 8051 Microcontroller and embedded system Using Assembly and C by Muhammad Ali Mazidi.
5. <http://www.keil.com/dd/docs/datasheets/phillips/p89v51rd2.pdf>.
6. <http://www.datasheetcatalog.org/datasheet/texasinstruments/max232.pdf>.
7. <http://positronindia.in/PT0006.aspx>