

# Design & Optimization of Microstrip Parallel Coupled Bandpass Filter at 20 GHz

Pooja Rani<sup>1</sup> ( M.Tech Student), Shilpi Gupta<sup>2</sup>( M.Tech Student), R. K. Prasad<sup>3</sup> (Associate Professor)

Department of Electronics & Communication<sup>1,2</sup>

Madan Mohan Malviya University of Technology, Gorakhpur

(Formerly Madan Mohan Malviya Engineering College, Gorakhpur)

**Abstract-** This paper presents a microstrip parallel coupled band pass filter with low insertion loss and wide pass band. Radio Frequency (RF) filters operating in the microwave frequency range which are needed for applications like radar and satellite communications while the infrared K band is used for astronomical observations. These applications demand high performance filters that can contribute as little as possible to a system's size and cost. This filter is planned to design and optimize at a center frequency of 20 GHz and operating between 19 GHz to 21 GHz range of frequencies. Advanced Design System (ADS 2011\_10) simulation tool is used to simulate a prototype of band pass filter using lumped and distributed component for using at 20 GHz cut off frequency. Roger 6010 type substrate has the relative permittivity of 10.2 and tangent loss of 0.0027 is used in designing the parallel coupled bandpass filter for K band application.

**Keyword-** BPF, Coupled line, Chebyshev response, Even and Odd impedance characteristics, Agilent ADS.

## I. INTRODUCTION

Microwave filter is a two port, reciprocal, passive, linear device which attenuates heavily the unwanted signal frequencies while permitting transmission of wanted frequency. In general, the electrical performance of the filter is described in terms of insertion loss, return loss, frequency selectivity (or attenuation at rejection band), group delay variation in the pass band and so on. Filters are required to have small insertion loss, large return loss for good impedance matching with interconnecting components and high frequency selectivity to prevent interference. To meet this trend, the band pass filters with relatively wide bandwidth are frequently required in the RF front ends. In microwave communication systems, the band pass filter is an essential component, which is usually used in both receivers and transmitters.

Band pass filter could either be realized using lumped components or distributed components. Lumped components consists of discrete elements like inductors, capacitors etc. Distributed elements consist of transmission line sections which simulate various inductance and capacitance values. It is hard to realize filters with lumped elements because at frequency above

1GHz, the dimensions of the electronic components are comparable with the wavelength of the signal as a result of which there could be distribute effects [1]. However transmission line filters are easy to implement and are compact at this frequency. A band pass filter allows transmission of frequencies in the pass band and attenuates frequencies in the stop band [1]. In this paper, we describe the design and simulation of a parallel coupled line (Fig.1) microstrip band pass filter with Chebyshev response. The design is simulated using ADS. The layout generated is simulated in Momentum.

Microstrip transmission line is the most used planar transmission line in Radio frequency (RF) applications. As other transmission line in RF applications, microstrip can also be exploited for designing certain components, like filter, coupler, transformer or power divider.

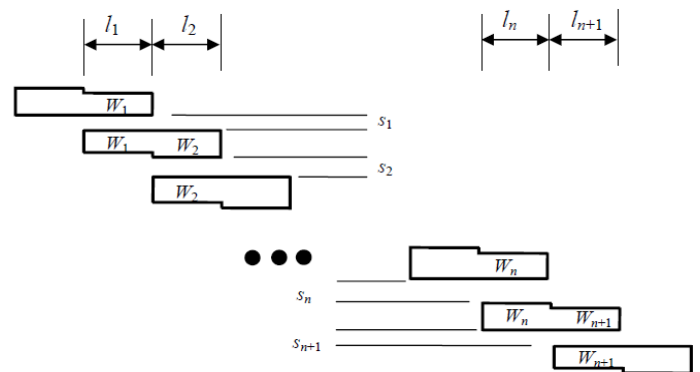

Fig.1: Parallel-coupled band pass filter.

## II. BPF CONFIGURATION AND DESIGN PROCEDURE

The microstrip filter specifications are as follows:

- Equal ripple Chebyshev Filter response
- Center frequency of 20 GHz
- Operating range 19 GHz to 21 GHz
- 3 dB bandwidth of 10.9%
- Pass band ripple of 0.5 dB

- Pass band attenuation 40 dB
- Source Impedance = 50 Ohms
- Substrate Roger 6010
- Relative permittivity of substrate ( $\epsilon_r=10.2$ )
- Thickness of substrate = 0.254
- Loss Tangent( $\tan \delta$ )=0.0027

$$g_k = \frac{4a_{k-1} a_k}{b_{k-1} \epsilon_{k-1}} \dots\dots 6$$

$$K=2,3,4,5 \dots\dots n$$

$$g_{m+1} = 1 \quad \text{if } n \text{ is odd} \quad \dots\dots 7$$

$$g_{m+1} = \coth^2 \left[ \frac{\beta}{4} \right] \quad \text{if } n \text{ is even} \quad \dots\dots 8$$

The specification for losses in pass region can normally be higher than zero in practical implementation. The Chebyshev approach shows certain ripples in the pass region, this can lead to better (higher) slope in the stop reason due to reason that Chebyshev approach losses in pass band region not so strictly given specification values but it can be 0.01 dB, or 0.1 dB, or even higher values.

Normalized element values for 0.5 dB ripple low-pass Chebyshev filter are calculated from above given equations. The normalized values are as follows [2].

$$g_1 = 1.5963=L_1, \quad g_2 = 1.0967=C_2, \quad g_3 = 1.5963=L_3, \quad g_4 = 1.000=Z_L$$

The values of Lumped elements are decided by normalized element values as shown above. The band pass filter can be realized as a cascade of N+1 coupled line section and the numbering of section is done from left to right as shown in Fig. 1. At the left the source is connected and the load is connected to the right. The filter could be reversed without affecting the response.

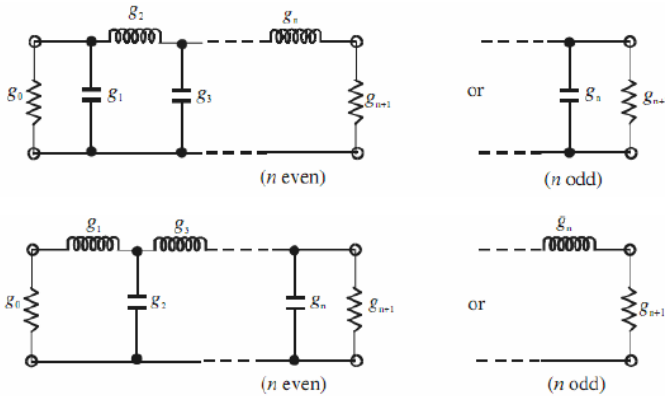

Fig.2: Realization of filter using LC components.

Fig.2 gives the circuit implementation of the filter by means of concentrated components like inductors (L) and capacitors (C), for the even and odd filter degree (n).

For the above filter specification we got the order of the filter n=3. The component values can be calculated with the following rules [6]

$$\beta = \ln \left( \coth h \frac{G_r}{17.37} \right) \dots\dots 1$$

Where  $G_r$  = ripples in pass band

$$\gamma = \sinh \frac{\beta}{2n} \dots\dots 2$$

$$a_k = \sin \left[ \frac{(2^k - 1)\pi}{2n} \right] \dots\dots 3$$

$$K = 1, 2, 3 \dots\dots n$$

$$b_k = \gamma^2 + \sin^2 \left[ \frac{K\pi}{n} \right] \dots\dots 4$$

$$K = 1, 2, 3 \dots\dots n$$

$$g_0 = 1, \quad g_1 = \frac{2a_1}{\gamma} \dots\dots 5$$

### III. TRANSFORMATION TO BANDPASS FILTER

In the transformation, the component L can be converted and represented to serial combinations of Ls and Cs, whereas the component C becomes parallel combination of Lp and Cp. We can calculate the center frequency and the relative frequency bandwidth as follows

$$\omega_0 = \sqrt{\omega_1 \omega_2} \quad \text{and} \quad \text{Frequency Bandwidth}(\Delta) = \frac{\omega_2 - \omega_1}{\omega_0}$$

And the values for the new components are shown below:

For the serial combination,

$$L_s = \frac{\epsilon_k Z_0}{\omega_0 \Delta}, \quad C_s = \frac{\Delta}{\epsilon_k \omega_0 Z_0} \dots\dots 9$$

And for the parallel combination.

$$C_p = \frac{\epsilon_k}{\omega_0 Z_0 \Delta}, \quad L_p = \frac{\Delta Z_0}{\epsilon_k \omega_0} \dots\dots 10$$

$Z_0$  is the value of the load impedance, normally set to 50  $\Omega$ . Corresponding values of serial and parallel combination of inductor and capacitor has been calculated and shown in table 1.

**Table 1** Calculated value of lumped component in Serial and Parallel Combination

Serial Combination	Parallel Combination
$L_1=6.354\text{nH}, C_1=0.00995\text{pF}$	$L_2=0.0363\text{nH}, C_2=1.7455\text{pF}$
$L_3=6.354\text{nH}, C_3=0.00995\text{pF}$	

The series and parallel combinations of inductors and capacitors have been used for designing band pass filter and design is simulated on Agilent Advanced Design System Software tool. Circuit diagram of band pass filter using lumped element has been shown in the Fig.3.

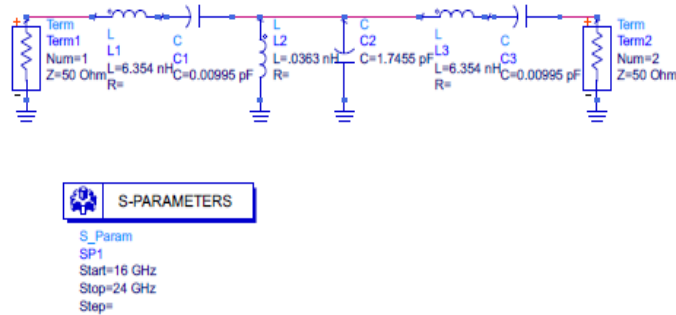

Fig. 3: Schematic diagram of BPF using L&C values in network.

This schematic diagram of the BPF using lumped element produces corresponding output waveform S(2,1) that is plotted with respect to frequency as shown in Fig.4. Graph shows that the signal attenuation at 18.85GHz is about -3.392dB and at 21.23GHz is about -3.398dB. Beyond 500MHz, filters with discrete components are difficult to realize because the wavelength becomes comparable with the physical filter element dimensions, resulting in various losses severely degrading the circuit performance. Thus to achieve at practical filters, the lumped component filters must be converted into distribution element realizations.

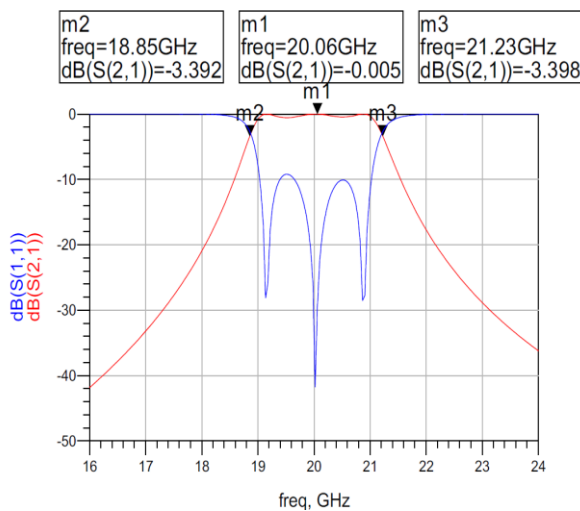

Fig 4: Output Wave form S parameters versus Frequency.

#### IV. FILTER REALIZATION WITH MICROSTRIP TECHNOLOGY

Microstrip transmission line is used for transport of wave with relative low frequency; the wave type propagating in this transmission line is a quasi-TEM wave. This is the fundamental mode in the microstrip transmission line. It has two propagation factors, even mode and odd mode. Fig.1 shows the filter structure observed in this work. This filter type is known as parallel-coupled filter. The strips are arranged parallel close to each other, so that they are coupled with certain coupling factors. We use the following equations for designing the parallel-coupled filter

First coupling structure

$$Z_0 J_1 = \sqrt{\frac{\pi \Delta}{2 \epsilon_1}} \quad \dots\dots 11$$

For intermediate structure

$$Z_0 J_n = \frac{\pi \Delta}{2 \sqrt{\epsilon_n} \epsilon_{n-1}} \quad \dots\dots 12$$

For final coupling

$$Z_0 J_{n+1} = \sqrt{\frac{\pi \Delta}{2 \epsilon_n \epsilon_{n+1}}} \quad \dots\dots 13$$

$g_0, g_1, \dots, g_n$  can be taken from above,  $\Delta$  is the relative bandwidth,  $J_n, J_{n+1}$  is the characteristic admittance of J inverter and  $Z_0$  is the characteristic impedance of the connecting transmission line.

With the data of characteristic admittance of the inverter, we can calculate the characteristic impedances of even-mode and odd-mode of the parallel-coupled microstrip transmission line. The characteristic impedance of these coupled lines can be specified in terms of even ( $Z_{0e}$ ) and odd ( $Z_{0o}$ ) impedances [2]. Even impedance is defined as the characteristic impedance of one line to ground when equal currents are flowing in the two lines. Odd impedance is defined as the characteristic impedance of one line to ground when equal and opposite currents is flowing in the two lines [2]. The odd and even impedances are calculated by the following equations

$$Z_{0e} = [1 + Z_0 J_{i,i+1} + (Z_0 J_{i,i+1})^2] Z_0 \quad \dots\dots 14$$

$$Z_{0o} = [1 - Z_0 J_{i,i+1} + (Z_0 J_{i,i+1})^2] Z_0 \quad \dots\dots 15$$

Even and odd impedances has been calculated for four sections and shown in table no 2.

**Table 2** Calculated value of J, Even and Odd Impedance

Stage	Z <sub>o</sub> J	Even Impedance(Ω)	Odd Impedance(Ω)
1	0.313611	70.598	39.237
2	0.118658	56.636	44.771
3	0.118658	56.636	44.771
4	0.313611	70.598	39.237

The length of each stage is chosen to be  $\lambda_g$  ( $\lambda_g$  is the guided wavelength), which corresponds to an electric length (Eeff) of  $90^\circ$ . Using Line Calc tool in ADS, the dimension of the microstrip line viz. length (L), width (W) and gap(S) between each other are calculated for the given odd and even impedances. Copper is used as conductor with thickness of 0.06mm and Roger 6010 having dielectric constant 10.20 with thickness 0.254 mm is used as substrate. The width, gap and length of each stage of the MCLIN (Microstrip Coupled-Line Filter Section) are derived, as illustrated in Table 3. To match with the 50 ohm circuit, MLIN (Microstrip Line) components are added to both sides of the filter whose characteristic impedance is 50 ohms. The length and width of the transmission line section is found using the Line Calc tool as 0.201593mm and 1.416360 mm.

**Table 3:** Calculated dimensions of transmission line sections

Stage	W(mm)	S(mm)	L(mm)
1	0.148802	0.167247	1.461160
2	0.173516	0.425682	1.405120
3	0.173516	0.425682	1.405120
4	0.148802	0.167247	1.461160

The structure of the filter is set up in ADS:

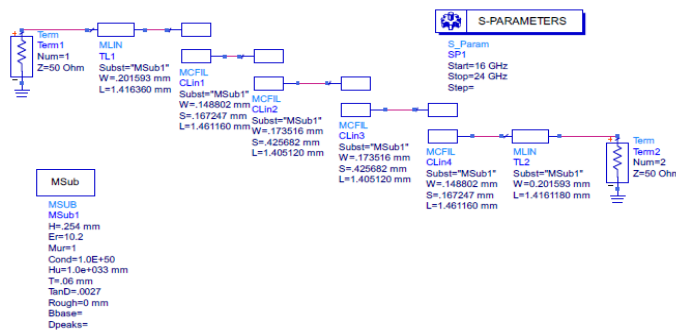

Fig. 5: Band pass filter model in ADS.

Parallel coupled lines are set up according to the values of W, S and L on ADS software tool and simulated. Output waveform of S parameter versus frequency has been observed and concluded that distributed circuit gives maximum attenuation of 15dB. We find out that the centre frequency of the filter has deviated from the specified frequency 20GHz. To reach the optimal or specified request we adopt the tuning design owing by ADS numerical software based on method of moment. We use VAR component to set the tunable parameter such as microstrip length. The parameter in VAR component should set around the values which we have calculated with conventional method.

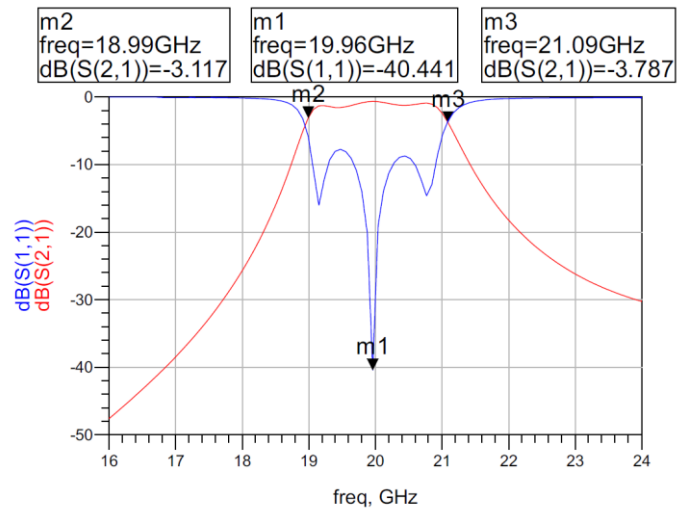

Fig. 6: Attenuation characteristics in pass-band after optimization.

The plot of amplitude versus frequency after optimization is shown in Fig.6. In the plot we can see clearly that the center frequency of the filter has been adjusted to 20GHz and the corresponding loss is less than 0.5dB. The reflect ratio in the pass band at 19.96GHz is -40.441dB indicating that the request performance is well satisfied.



Fig. 7 Layout of parallel-coupled microstrip band pass filter.

Layout of filter is generated from the schematic design. The layout of the filter is shown in Fig. 7. This figure gives four resonator built by four pairs of parallel-coupled microstrip. In

the pass band because of ripples, Chebyshev band pass filter has non linear phase but better slope.

## V. CONCLUSION

By using Chebyshev approach, designing of band pass filter in combination with concentrated components, i.e. inductors and capacitors and its computational verification in form of parallel coupled microstrip lines with Agilent ADS simulation tool gives very good filter characteristics at the center frequency 20 GHz. By analyzing  $S_{11}$  response, shows 3 order ripples which prove this filter has a Chebyshev band pass filter response. In microstrip coupled lines if separation is small the even mode impedances is high and odd mode impedance is low. We see a resonant at desired frequency of 20GHz with reflection factor smaller than -40dB. The insertion loss occurring in  $S(2,1)$  of about -5dB , primarily due to the tangent loss of the substrate.

## REFERENCES

- [1] D. M. Pozar, "Microwave Engineering," 3rd ed New york, Wiley, 2012, pp. 367-368.
- [2] George L. Matthaei, Leo Young, E. M. T. Jones. *Microwaves Filters, Impedance- Matching Networks, and Coupling Structures*. Reprint of the edition by McGraw-Hill. Dedham: Artech House, 1980.
- [3] Bin Dong, Quanyuan Feng , Shuai Yang," Research and Design of X-band SIR Microstrip Filters", Natural Science. Foundation of China and China Academy of Engineering Physics under the grant No.10876029.
- [4] Ralph Levy, Fellow IEEE, and Seymour B Cohn, Fellow," A History of Microwave Filter Research, Design, and Development", IEEE Transactions On Microwave Theory And Techniques, Vol. Mtt-32, No. 9, Septemrer 1984.
- [5] K. Rajasekaran, J. Jayalakshmi and T. Jayasankar," Design and Analysis of Stepped Impedance Microstrip Low Pass Filter Using ADS Simulation Tool for Wireless Applications", International Journal of Scientific and Research Publications, Volume 3, Issue 8, August 2013 1 ISSN 2250-3153.
- [6] Jayaseelan Marimuthu, Amin M. Abbosh, and Bassem Henin," Planar Microstrip Bandpass Filter With Wide Dual Bands Using Parallel-Coupled Lines And Stepped Impedance Resonators", Progress In Electromagnetics Research.
- [7] M. Kirschning and R.H. Jansen, "Accurate wide-range design equations for the frequency-dependent characteristic of parallel coupled microstrip lines," IEEE Transactions on Microwave Theory and Techniques, vol. 32, no. 1, pp. 83-90, Jan. 1984.
- [8] M. Kirschning and R.H. Jansen, "Corrections to "Accurate wide-range design equations for the frequency-dependent characteristic of parallel coupled microstrip lines," IEEE Transactions on Microwave Theory and Techniques, vol. 33, no. 3, p. 288, Mar. 1985.
- [9] I. Hunter, R. Ranson, A. Guyette, and A. Abunjaileh, "Microwave filter design from a systems perspective," IEEE Microwave Magazine, vol. 8, no. 5, p. 71, Oct. 2007.
- [10] R. V. Snyder, "Practical aspects of microwave filter development," IEEE Microwave Magazine, vol. 8, no. 2, pp. 42-54, Apr. 2007.
- [11] P. W. Wong and I. Hunter, "Electronically tunable filters," IEEE Microwave Magazine, vol. 10, no. 6, pp. 46-54, Oct. 2009.
- [12] J. M. Drozd and W. T. Joines, "Maximally flat quarter wavelength- coupled transmission-Line filters using Q distribution," IEEE Trans. Microwave Theory Tech., vol. 45, no.12, pp.2100-2113, Dec. 1997. [13] J.-T. Kuo and E. Shih, "Wideband bandpass filter design with three-line microstrip structures," 2001 IEEE MTT-S Int. Microwave Symp. Dig., pp. 1593-1596.
- [14] A. Saito, H. Harada and A. Nishikata, "Development of bandpass filter for ultra wideband (UWB) communication systems," 2003 IEEE Conference on Ultra Wideband Systems and Technologies, pp. 76-80, Nov. 2003
- [15] Ching-Luh Hsu, Fu-Chieh Hsu, and Jen-Tsai Kuo, Microstrip Bandpass Filters for Ultra Wide Band (UWB) Wireless Communication, Microwave Symposium Digest, 2005 IEEE MTT-S International, 12-17 June 2005.